

1 kHz single-frequency, injection-seeded Er:YAG laser with an optical feedback

Yixuan Zhang (张艺轩), Chunqing Gao (高春清)*, Qing Wang (王庆),
Quanxin Na (纳全鑫), Meng Zhang (张濛), Mingwei Gao (高明伟),
and Shuai Huang (黄帅)

School of Optics and Photonics, Beijing Institute of Technology, Beijing 100081, China

*Corresponding author: gao@bit.edu.cn

Received September 10, 2018; accepted December 14, 2018; posted online March 4, 2019

A novel 1 kHz single-frequency, Q -switched Er-doped yttrium aluminum garnet (Er:YAG) laser pumped by a 1470 nm laser diode is demonstrated. The 500 ns, 5.52 mJ single-frequency, diffraction-limited pulses are obtained by using a ‘ramp-fire’ injection-seeding technique and an optical feedback architecture. The full width at half-maximum of the pulse spectrum is measured to be 1.47 MHz by using the heterodyne technique. The beam quality M^2 factors are measured to be 1.18 and 1.24 in the x and y directions, respectively.

OCIS codes: 140.3520, 140.3280, 140.3540.

doi: 10.3788/COL201917.031402.

Solid-state, single-frequency, Q -switched lasers have many applications, such as coherent Doppler Lidar, differential absorption Lidar, and coherent imaging Lidar^[1-6]. A common way to achieve stable operation of a single-frequency, Q -switched laser is to inject a stable continuous wave (CW), single-longitudinal-mode laser into a Q -switched slave laser with high energy. The ‘ramp-fire’ technique is an effective way to ensure successful injection seeding^[7,8].

For the coherent Doppler Lidar applications, the figure of merit (FOM), defined as the product of the pulse energy and the square root of pulse repetition frequency (PRF), strongly determines the detection capability of the Lidar system. Increasing the PRF improves not only the signal-to-noise ratio (SNR) but also the detection range by signal averaging. Thus, when the output energy is fixed, a higher repetition rate could improve the detection capability of the Doppler Lidar system^[9].

In the last decade, 1.6 μm Er-doped yttrium aluminum garnet (Er:YAG) lasers have attracted widespread interests for their operation in regions of high atmospheric transmission and eye-safe wavelengths. Many research groups demonstrated various 1.6 μm Er:YAG lasers used in a Lidar system. In 2010, Chang *et al.* reported a resonantly diode-pumped, CW, and Q -switched Er:YAG laser at 1645 nm^[9]. In 2014, Deng *et al.* reported a 100 Hz single-frequency, injection-seeded, Q -switched Er:YAG laser with a pulse energy of 3.5 mJ and a pulse width of 195 ns^[10]. In 2015, Yao *et al.* developed a single-frequency, injection-seeded Er:YAG laser based on a bow-tie ring slave laser. The output energy of 2.9 mJ is achieved at a PRF of 100 Hz^[11]. In 2015, Yu *et al.* reported a narrow-linewidth, linearly polarized, passively Q -switched 1645 nm Er:YAG laser with a pulse energy of 58.8 μJ and a pulse width of 4.21 μs at a PRF of 53.2 kHz^[12]. In 2016, Ye *et al.* reported a single-frequency, injection-seeded, Q -switched Er:YAG ceramic laser with a pulse energy

of 4.7 mJ and a pulse width of 250 ns at a PRF of 200 Hz^[13]. However, a high-repetition-rate, single-frequency, Q -switched Er:YAG laser pumped by a laser diode (LD) has not been reported yet.

In this Letter, we demonstrate a novel 1 kHz single-frequency, injection-seeded, Q -switched Er:YAG laser with a pulse energy of 5.52 mJ and a pulse width of 500 ns. A stable Er:YAG non-planar ring resonator (NPRO) laser with a power of 700 mW is utilized as the seed laser. A ‘bow-tie’ ring cavity resonantly pumped by a 1470 nm LD is employed as the slave laser. In order to suppress the bi-directional operation and define the direction of the laser emission during injection seeding, a flat mirror is placed behind the output coupler to provide an optical feedback. The M^2 factors of the Q -switched, injection-seeded laser are measured to be 1.18 and 1.24 in the x and y directions, respectively. The full width at half-maximum (FWHM) of the pulse spectrum is measured to be 1.47 MHz by the heterodyne beating technique. To the best of our knowledge, this is the first time to report a diode-pumped, high-repetition-rate, single-frequency, Q -switched Er:YAG laser with an optical feedback. Benefitting from the optical feedback, the stable, single-frequency, un-directional operation is achieved, which largely increases the optical efficiency.

The schematic of the single-frequency, Q -switched Er:YAG laser is shown in Fig. 1. The laser system consists of four parts: a stable NPRO laser (seed laser), a Q -switched ‘bow-tie’ ring resonator (slave laser), a ‘ramp-fire’ electronic controlling system for injection seeding, and a heterodyne beating system.

A stable, single-longitudinal-mode Er:YAG NPRO laser pumped by a fiber-coupled 1470 nm LD is utilized as the seed laser. The output power of the Er:YAG NPRO laser is 700 mW. The pump beam is focused by a plano-convex mirror f2 with a focal length of 100 mm. An isolator is employed to protect the seed laser from the

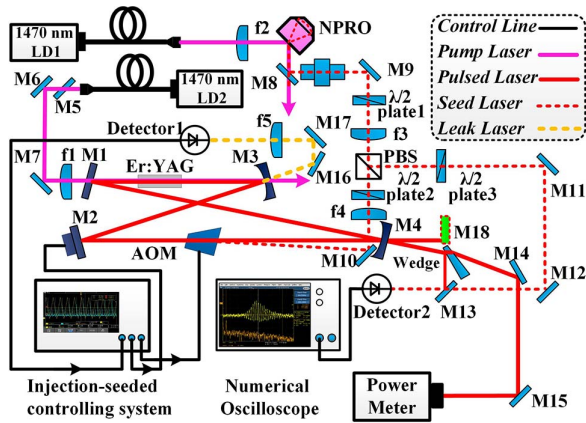

Fig. 1. Schematic diagram of the 1 kHz injection-seeded, Q-switched Er:YAG laser.

feedback of the backward pulses. A half-wave plate ($\lambda/2$ plate1) and a polarized beam splitter (PBS) are used to split the seed laser into two parts: one (500 mW) is injected into the slave cavity through the first diffraction order of the acousto-optic modulator (AOM), and the other (200 mW) is used as reference of the heterodyne beating system. The polarization state of the injected seed laser is set to p polarized with a half-wave plate ($\lambda/2$ plate2) for the convenience of injection seeding.

To eliminate the effects of spatial hole burning, a ‘bow-tie’ ring cavity configuration is employed for the slave laser. The slave laser consists of two flat mirrors and two curved mirrors. M1 and M2 are 0° dichroic flat mirrors coated for high reflectivity at 1645 nm and high transmission at 1470 nm. M2 is mounted upon a piezoelectric actuator (PZT) to achieve the precise adjustment of the cavity length. M3 is a dichroic curved mirror with a radius of curvature of 500 mm. It is also coated for high reflectivity at 1645 nm and high transmission at 1470 nm just like M1 and M2. M4, a plano-concave mirror with a radius of curvature of 500 mm, is employed as the output coupler of the slave laser. It is coated for 20% transmission at 1645 nm. A 60-mm-long Er:YAG crystal with an Er doping concentration of 0.25 at. % is employed as the gain medium. Both end surfaces of the Er:YAG crystal are antireflection coated in the wavelength range of 1470 to 1645 nm. The crystal is wrapped in indium foil and clamped in a copper heat sink, which is maintained at 18°C by a thermoelectric cooler (TEC). The slave laser is end-pumped by a 1470 nm fiber-coupled LD. The maximum incident pump power is 41 W. M6 and M7, which are both 45° flat mirrors coated for high reflectivity at 1470 nm, are employed to fold the pump beam. The plano-convex lens (f1) with a focal length of 125 mm is employed to focus the collimated pump beam. M5 is a dichroic mirror coated for high reflectivity at 1645 nm and high transmission at 1470 nm. It is employed to protect the pump source from damage caused by backward leaking pulses. A fused silica AOM is inserted into the slave cavity to achieve the Q-switched

operation and injection seeding. The radio frequency of the AOM is 68 MHz.

In order to achieve stable, single-frequency, injection-seeded operation by using the ‘ramp-fire’ technique, a complex programmable logic device controlling system is used. A digitized periodic voltage is amplified to drive the PZT, and the interference signal leaking through M3 is observed by the photodiode (Detector1). M16 and M17 are 45° dichroic flat mirrors coated with high reflectivity at 1645 nm and high transmission at 1470 nm. They are utilized to fold the resonance beam into Detector1. In order to amplify the resonance signal, the plano-convex lens (f5) with a focal length of 200 mm is employed to focus the resonance beam. The peak of the resonance signal appears when the seed laser is resonant with the slave laser. Once the peak is detected, a latch signal is given to the AOM driver to fire the injection-seeded, single-frequency, Q-switched pulse.

The heterodyne beating system is employed to test the performance of the ‘ramp-fire’ electronic controlling system and measure the spectral linewidth of the single-frequency pulse. The single-frequency output pulse reflected by the wedge is spatially mixed with the seed laser (200 mW) by M13, which is an uncoated 45° flat mirror. The mixed signal is detected with another InGaAs photodiode (Detector2) and then recorded by a digital oscilloscope (TDS5025B, Tektronix).

The CW output power of the Er:YAG laser as a function of the pump power is shown in Fig. 2. The maximum output power of 6.15 W is obtained with a slope efficiency of 36.7%.

When injection-seeded, the average output power as a function of PRF is shown in Fig. 3. When the PRF is below 500 Hz, the average output power increases with the increase of PRF, and the maximum average output power of 4.92 W is obtained at a PRF of 500 Hz. However, when PRF is above 500 Hz, the average output power decreases dramatically with the increase of PRF because of the bi-directional instead of un-directional operation. In addition, the injection-seeded Er:YAG laser suffers from poor

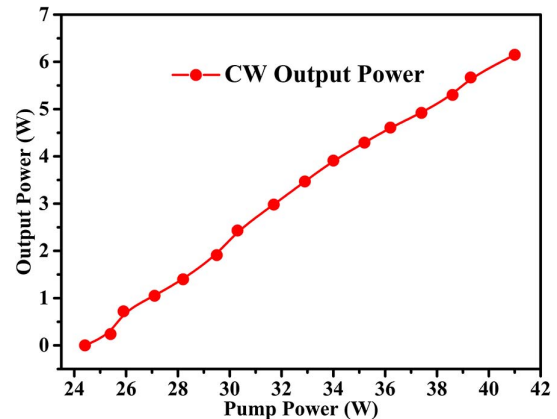

Fig. 2. CW output power of the slave laser versus the pump power.

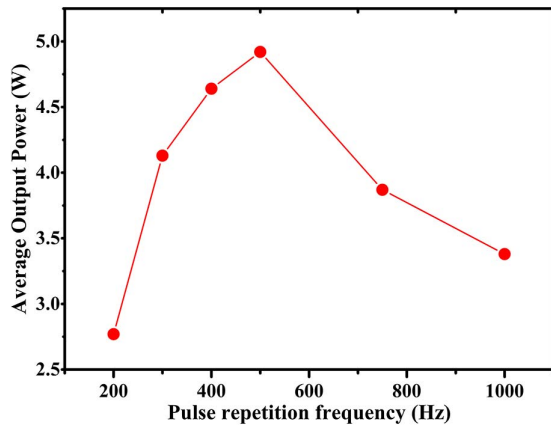

Fig. 3. Average output power of the single-frequency, injection-seeded laser as a function of PRF.

stability of the output energy at PRFs of 750 Hz and 1 kHz due to the bi-directional laser emission.

The heterodyne beating system is built to characterize the performance of the electronic controlling system. As the seed laser is injected into the slave laser from the first diffraction order of the AOM, the frequency of the injected seed laser is shifted by 68 MHz. The heterodyne beating signal is detected by Detector2 and recorded by the digital oscilloscope. The heterodyne beating signal and its fast Fourier transform (FFT) spectrum are shown in Fig. 4(a), which indicates that single-longitudinal-mode lasing is achieved, and the central frequency of the heterodyne beating signal is 69.92 MHz.

The laser pulses output in another direction (un-injection-seeded direction) are also detected, and smooth temporal profiles of the pulse are observed, which indicates single-longitudinal-mode lasing. To further confirm that, a heterodyne beating system is built to analyze the pulse spectrum. The heterodyne beating signal and its FFT spectrum are shown in Fig. 4(b), which indicates a high spectral purity without any other harmonic components within 30 dB of the main peak. The central frequency of the heterodyne beating signal is measured to be 69.14 MHz. The results indicate that even if the resonator is injection-seeded and operates in single longitudinal mode, it is also possible to operate the Er:YAG laser transmitter pumped by an LD in the bi-directional mode. What is more, the laser characteristics of the single-frequency output pulses emitting in two directions are almost the same, which is very enlightening for providing an ideal method to achieve stable, high-efficiency, LD-pumped, single-frequency operation at a high PRF. A 0° flat mirror (M18) is employed behind the output coupler to define the direction of the laser emission. After placing M18 behind the output coupler, the bi-directional operation is totally suppressed, and the stable 1 kHz un-directional, single-frequency operation is achieved. Adding M18 is equivalent to providing an optical feedback for improving the gain of the injection-seeded direction.

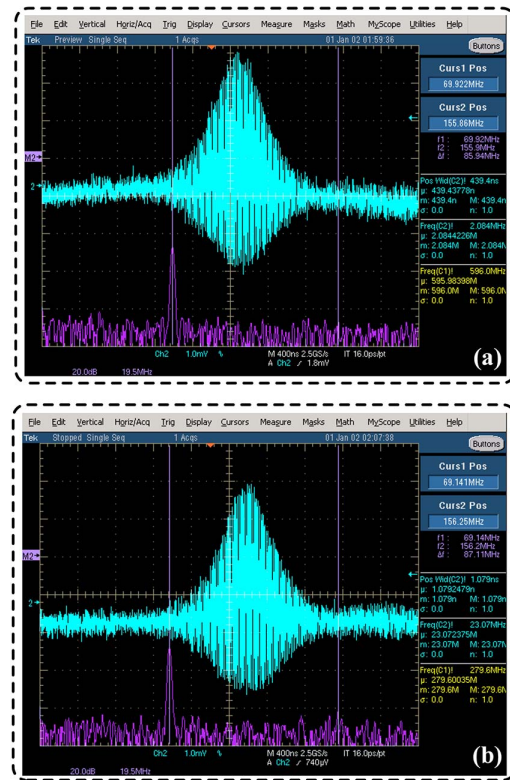

Fig. 4. (a) Heterodyne beating signal and the FFT spectrum of the heterodyne beating signal in injection-seeded output direction. (b) Heterodyne beating signal and the FFT spectrum of the heterodyne beating signal in un-injection-seeded output direction.

The output energies of the injection-seeded laser with an optical feedback obtained at the PRFs of 500 Hz, 750 Hz, and 1 kHz are compared, as shown in Fig. 5. The output energy increases linearly with the increase of the pump power. The maximum output energies of 9.84 mJ, 6.95 mJ, and 5.52 mJ are obtained at PRFs of 500 Hz, 750 Hz, and 1 kHz, respectively. The corresponding pulse widths are measured to be 353.7 ns, 420.5 ns, and 500.0 ns, respectively. Compared to the injection-seeded

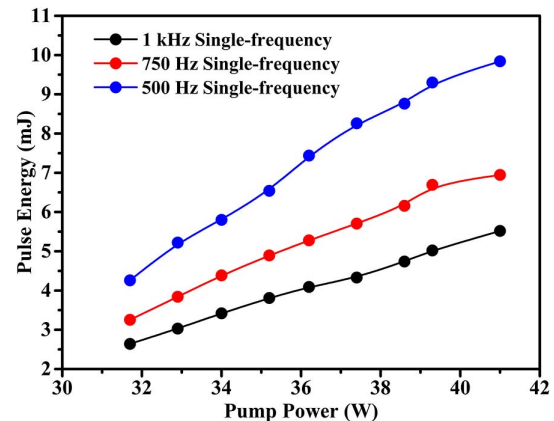

Fig. 5. Output energy of the single-frequency, injection-seeded laser with suppression mirror as a function of the pump power.

laser without M18, the output energy of the injection-seeded laser with M18 improves largely at PRFs of 750 Hz and 1 kHz. This is because when M18 is employed, the bi-directional emission of the ring laser is suppressed, which contributes to higher optical efficiency.

The pulse build-up time of the Q -switched Er:YAG laser at a PRF of 1 kHz is presented in Fig. 6. The pulse build-up time decreases with the increase of the pump power. At a fixed pump power, the pulse build-up time of the injection-seeded laser is much shorter. This is because the laser pulse is built from the weak seed laser instead of spontaneous emission in the injection-seeded mode.

The heterodyne beating system is built to measure the pulse spectrum of the injection-seeded, Q -switched Er:YAG laser with an optical feedback. The heterodyne beating signal is shown in Fig. 7(a). The spectral intensity profile of the beating waveform is analyzed by an FFT technique, as shown in Fig. 7(b). The central frequency of the heterodyne beating signal is measured to be 70.09 MHz. The spectral intensity profile of the heterodyne beating signal fits with the Gaussian distribution, and the FWHM of the pulse spectrum is measured to be 1.47 MHz.

Under the maximum pump power, the fluctuation of the relative central frequency of the laser pulses is measured for 1 h with our homemade LabVIEW software. The root mean square (RMS) is 1.65 MHz, and the mean is 69.19 MHz.

The M^2 factors of the single-frequency, injection-seeded laser under the maximum pump power are measured by using 10-90 knife-edge technique. The beam diameters at different positions along the beam propagation are shown in Fig. 8. The picture inserted is a beam profile of the single-frequency pulsed laser. By fitting the beam diameters with a hyperbolic curve, the M^2 factors are calculated to be 1.18 and 1.24 in the x and y directions, respectively, which indicate that the injection-seeded, pulsed laser is in transmission electron microscopy (TEM₀₀) mode oscillation.

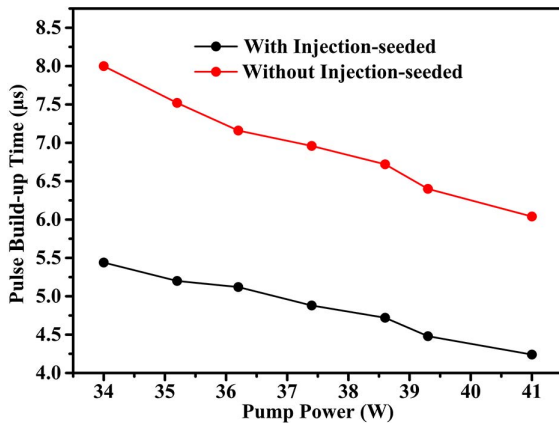

Fig. 6. Pulse build-up time of the single-frequency, injection-seeded laser with M18 as a function of the pump power.

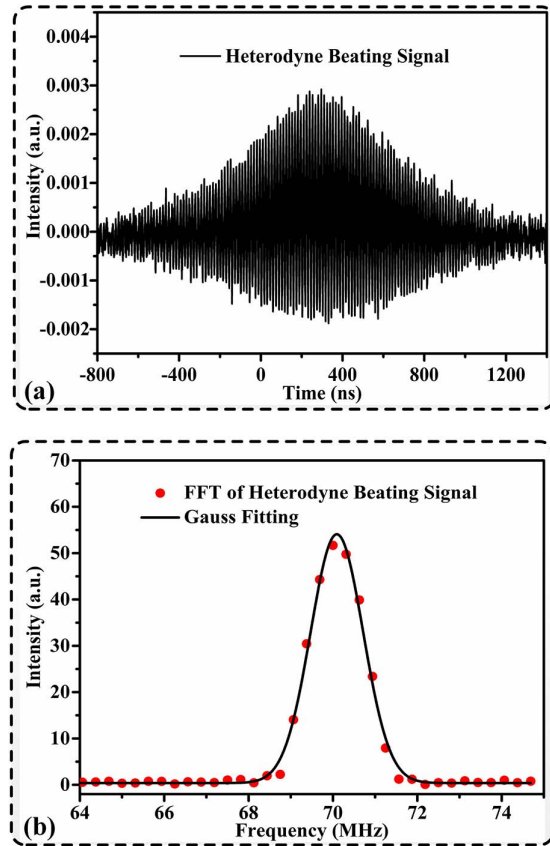

Fig. 7. (a) Heterodyne beating signal of the single-frequency, injection-seeded laser. (b) FFT of the heterodyne beating signal with self-feedback as a function of the pump power.

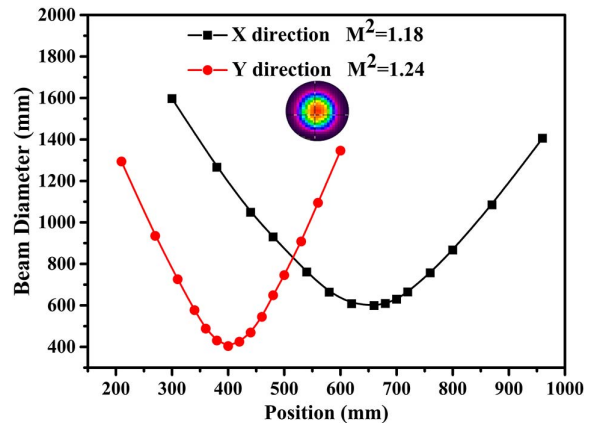

Fig. 8. M^2 factors of the single-frequency, injection-seeded, Q -switched laser.

Under the maximum pump power of 41 W, the fluctuation of the output energy for the PRF of 1 kHz is measured for 1 h, and the results are shown in Fig. 9. The RMS of 0.94% is achieved, and the mean is measured to be 5.52 mJ. Benefitting from the optical feedback, the stability of the output energy for 1 kHz improves largely, which has great potential for the application of coherent Doppler Lidar.

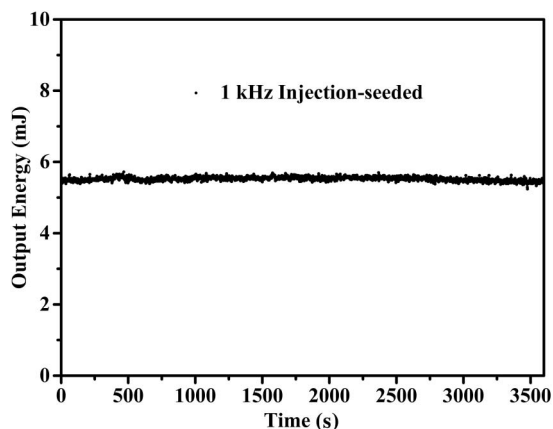

Fig. 9. Fluctuation of the output energy at the highest output level.

In summary, we report a novel high-repetition-rate, single-frequency, injection-seeded, Q -switched Er:YAG laser with an optical feedback. The 5.52 mJ, 500 ns single-frequency, diffraction-limited laser pulses at a PRF of 1 kHz are obtained. The spectral linewidth of the single-frequency pulsed laser is measured to be 1.47 MHz by the heterodyne beating technique. The fluctuation of the output energy under the maximum incident pump power is measured to be 0.91% (RMS) in 1 h. The measured M^2 factors are 1.18 and 1.24 in the x and y directions, respectively.

For achieving stable, single-frequency, un-directional operation, a flat mirror is employed behind the output coupler to provide an optical feedback. It is the first time, to the best of our knowledge, to report a single-frequency, injection-seeded laser with an optical feedback, which is capable of realizing stable, single-frequency, un-directional operation. In addition, the optical feedback also contributes

to realizing high optical efficiency and stable output energy of the high-repetition-rate, injection-seeded laser pumped by an LD. The single-frequency, Q -switched Er:YAG laser pumped by a 1470 nm LD has great potential as the optical source of coherent Doppler Lidar.

This work was supported by the National Natural Science Foundation of China (NSFC) (No. 61627821) and the National Key Research and Development Program of China (No. 2017YFB0405203).

References

1. R. C. Stoneman, R. Hartman, A. I. R. Malm, and P. Gatt, Proc. SPIE **5791**, 167 (2005).
2. S. Hannon, K. Barr, J. Novotny, J. Bass, A. Oliver, and M. Anderson, in *European Wind Energy Conference and Exhibition*, Brussels, Belgium (2008), p. 1.
3. S. Nikolov and L. Wetenskap, Electron. Lett. **31**, 731 (1995).
4. J. Buck, A. Malm, A. Zakel, B. Krause, and B. Tiemann, Proc. SPIE **6550**, 655002 (2007).
5. J. T. Wang, J. Zhou, G. H. Zang, X. L. Zhu, and W. B. Chen, Chin. Opt. Lett. **8**, 670 (2010).
6. X. P. Zhu, J. Q. Liu, D. C. Bi, J. Zhou, W. F. Diao, and W. B. Chen, Chin. Opt. Lett. **10**, 012801 (2012).
7. G. J. Koch, J. P. Deyst, and M. E. Storm, Opt. Lett. **18**, 1235 (1993).
8. S. W. Henderson, C. P. Hale, J. R. Magee, M. J. Kavaya, and A. V. Huaker, Opt. Lett. **16**, 773 (1991).
9. N. W. Chang, N. Simakov, D. J. Hosken, J. Munch, D. J. Ottaway, and J. Veitch, Opt. Express **18**, 13673 (2010).
10. Y. Deng, X. Yu, B. Q. Yao, T. Y. Dai, X. M. Duan, and Y. L. Ju, Laser Phys. **24**, 045809 (2014).
11. B. Q. Yao, Y. Deng, T. Y. Dai, X. M. Duan, Y. L. Jun, and Y. Z. Wang, IEEE J. Quantum Electron. **45**, 709 (2015).
12. Z. Z. Yu, M. J. Wang, X. Hou, and W. B. Chen, Chin. Opt. Lett. **13**, 071403 (2015).
13. Q. Ye, C. Q. Gao, S. Wang, Q. X. Na, Y. Shi, Q. Wang, M. W. Gao, and J. Wang, Appl. Phys. B. **122**, 198 (2016).